

- 1 Uncompromising - the most effective cleansing of current that may be generally achieved with separation transformers. Utmost pleasure of sound .

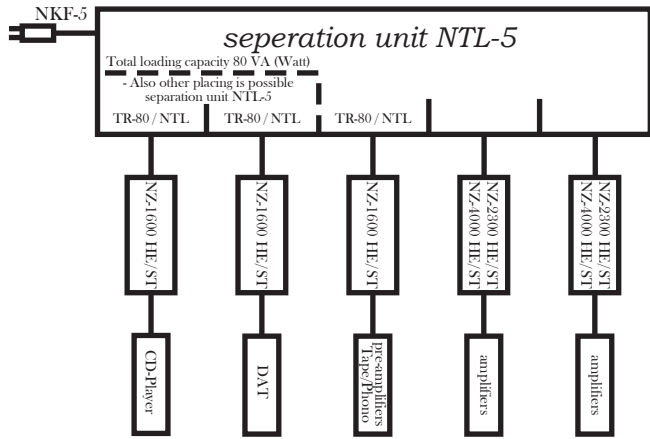

- 2 Configuration 2 provides a sensible external cleansing of the net, by strongly calming down and softening the 50 Hz-Sine. The entire equipment will benefit from this process which will lead to an extremely calm, dissolved sound picture, rich in impulse.

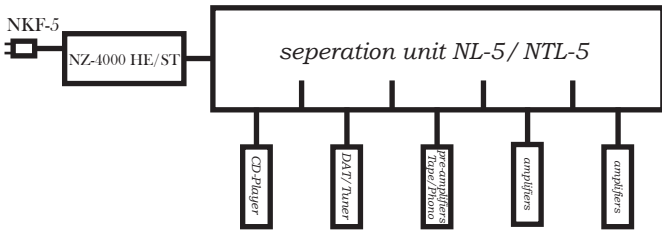

Also the NZ-2-Channel - and 3-Chanel-Netfilters are an excellent choice for separation transformers.

- 3 Configuration 3 shows examples of alternative ways of usage.

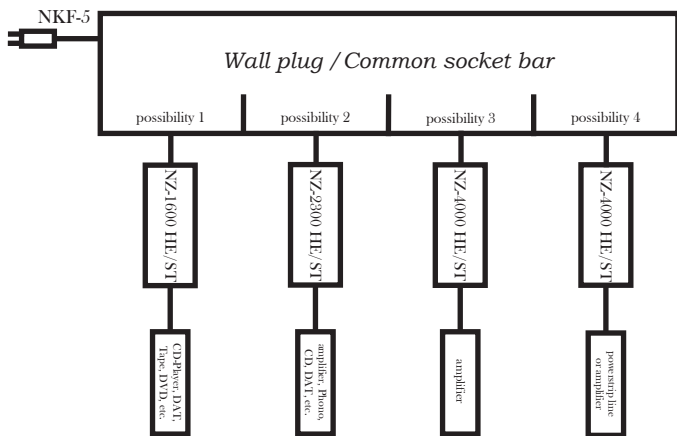

- 4 Configuration 4 shows the alternative solution with separation transformers.

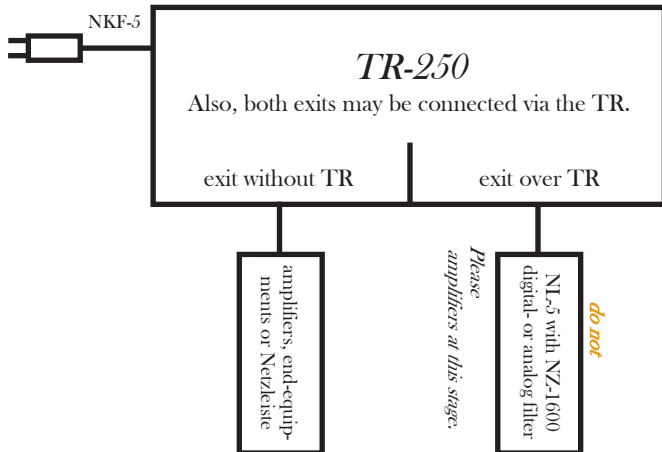

- 5 Configuration 5 shows alternative forms of usage of the NZ-2K HE.

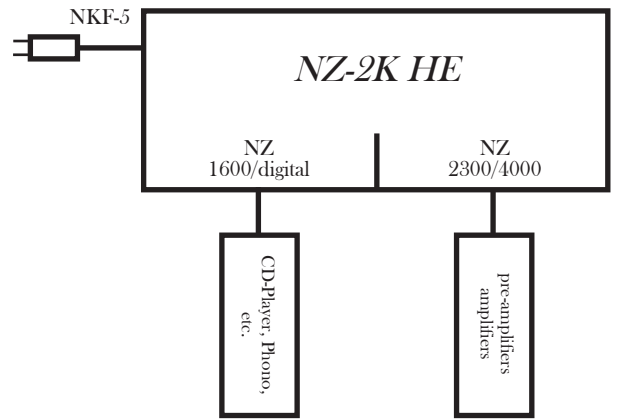

- 6 Configuration 6 shows alternative forms of usage of the NZ-3K HE.

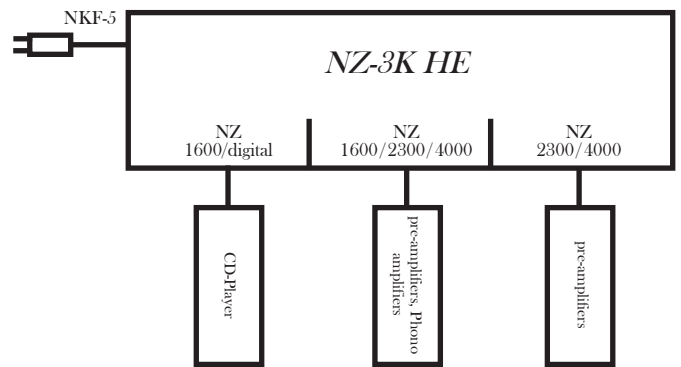

- 7 Configuration 7 shows a possible form of assembly for the NZ-5K.

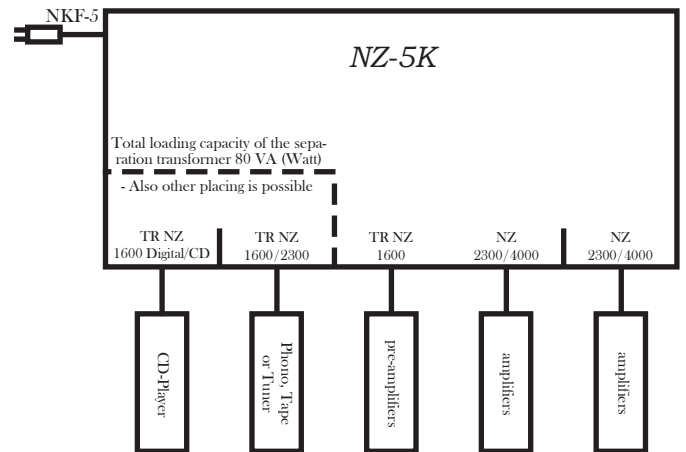

Main supply Power cord NKF-5/Gold 1,0 / 1,5 / 2,0 m (also longer)

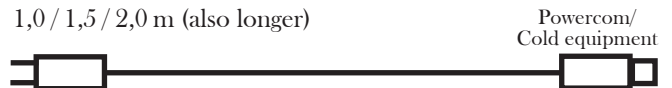

Main supply Power cord NKF-5/Gold-active 1,0 / 1,5 / 2,0 m (also longer)



connect any